

PCOM-B801GT

COM-HPC Server, Size D Module with Intel Atom® P5300 series processors, up to 4 DDR4 SO-DIMM (select by SKU) and support 8 port 10Gbe KR/4 port 25Gbe KR

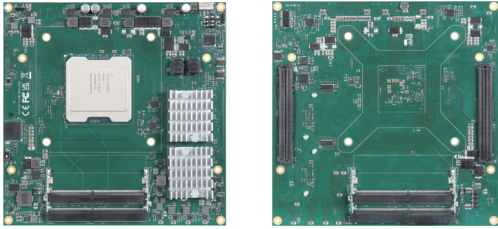

(preliminary spec subject to change)

FEATURES

- Intel Atom® P5300 series Processors up to 83W TDP
- COM-HPC Server, Size D
- Support up to 4 x DDR4 SO-DIMMs (select by SKU) and 2667MT/s
- All SKUs i.Temp and QAT support
- x16 PCIe Gen 3 Lanes, x8 10Gbe KR (Optional 4x 25Gbe KR)
- Optional Dual NVMe SSD Chip (one x4 or two x2) maximum size up to 1TB x2



The PCOM-B801GT, a COM-HPC Server Size D module powered by the Intel® P5300 family with up to 24 cores and 83W TDP, supports up to 4 SO-DIMM slots and offers wide temperature range options across all SKUs. With Intel QuickAssist Technology (QAT) of up to 100Gbps (select SKUs), it accelerates cryptographic and compression tasks.

The PCOM-B801GT is ideal for demanding applications such as Ethernet Switch Control Plane, Outdoor 5G Small Cell, and SD-WAN, providing up to 8x 10GbE KR ports or an optional 4x 25GbE KR for versatile networking options. Additionally, it supports onboard NVMe storage with either one x4 or two x2 configurations as options, ensuring high-speed data access and flexibility.

GENERAL INFORMATION

Product	PCOM-B801GT				
Form Factor	COM-HPC Server Size D (160mm x 160mm)				
Processor	Intel Atom® P5300 series				
	P5322	P5332	P5342	P5352	P5362
Core / Thread Count	8C/8T	12C/12T	16C/16T	20C/20T	24C/24T
Base Frequency	2.2GHz	2.2GHz	2.2GHz	2.2GHz	2.2GHz
Boost Frequency	2.2GHz	2.2GHz	2.2GHz	2.2GHz	2.2GHz
Cache	9M	13.5M	18M	22.5M	27M
Integrated Ethernet / QAT	100G / 50G	100G / 50G	100G / 100G	100G / 100G	100G / 100G
NBASE-T	Intel® I226IT				
Processor TDP	55W	61W	71W	78W	83W
ECC Memory Supported	Yes				
Memory	3 x SO-DIMM	3 x SO-DIMM	3 x SO-DIMM	4 x SO-DIMM (backside 8mm high)	4 x SO-DIMM (backside 8mm high)
Temperature Range	-40 ~ 85 °C	-40 ~ 85 °C	-40 ~ 85 °C	-40 ~ 85 °C	-40 ~ 85 °C

I/O INTERFACE

SATA	2 x SATA III	
USB	4 x USB 3.2 Gen1 / USB 2.0	
Ethernet	8 x 10Gbe KR (option 4 x 25Gbe KR) 2.5Gbe LAN	
Serial I/O	GPIO	12 bit GPIO
	I ² C	Baud Rate : 100KHz
	SMBus	Baud Rate : 100KHz
	UART	2 Serial Port (TX/RX/CTS/RTS)
PCI Express	16 Lanes PCIe Gen3 Support 1x16, 2x8, 4x4 bifurcation 4 Lanes PCIe Gen2 Support 1x4, 2x2 bifurcation 4 Lanes PCIe Gen2 Support 2x2 bifurcation (optional on board SSD : one x4 NVMe chip or two x2 NVMe chip)	
Security	TPM 2.0	

MECHANICAL & ENVIRONMENT

Dimension	160mm x 160mm
Power DC IN	Normal: +12V DC AT/ATX mode
Storage Temperature	-40 ~ 85 °C
Operating Temperature	-40 ~ 85 °C
Certification	Contact us
MTBF	Contact us
Vibration	Contact us
OS	Linux

ORDERING GUIDE

Product	Ordering P/N	Status
PCOM-B801GT-P5322	AB1-3S67Z	In Development
PCOM-B801GT-P5332	AB1-3S68Z	In Development
PCOM-B801GT-P5342	AB1-3S69Z	In Development
PCOM-B801GT-P5352	AB1-3S71Z	In Development
PCOM-B801GT-P5362	AB1-3S70Z	In Development

Accessory	Ordering P/N	Status
Heat spreader	TBD	In Development
Heat sink	TBD	In Development
2U cooler	TBD	In Development

BLOCK DIAGRAM

PCOM-B801GT

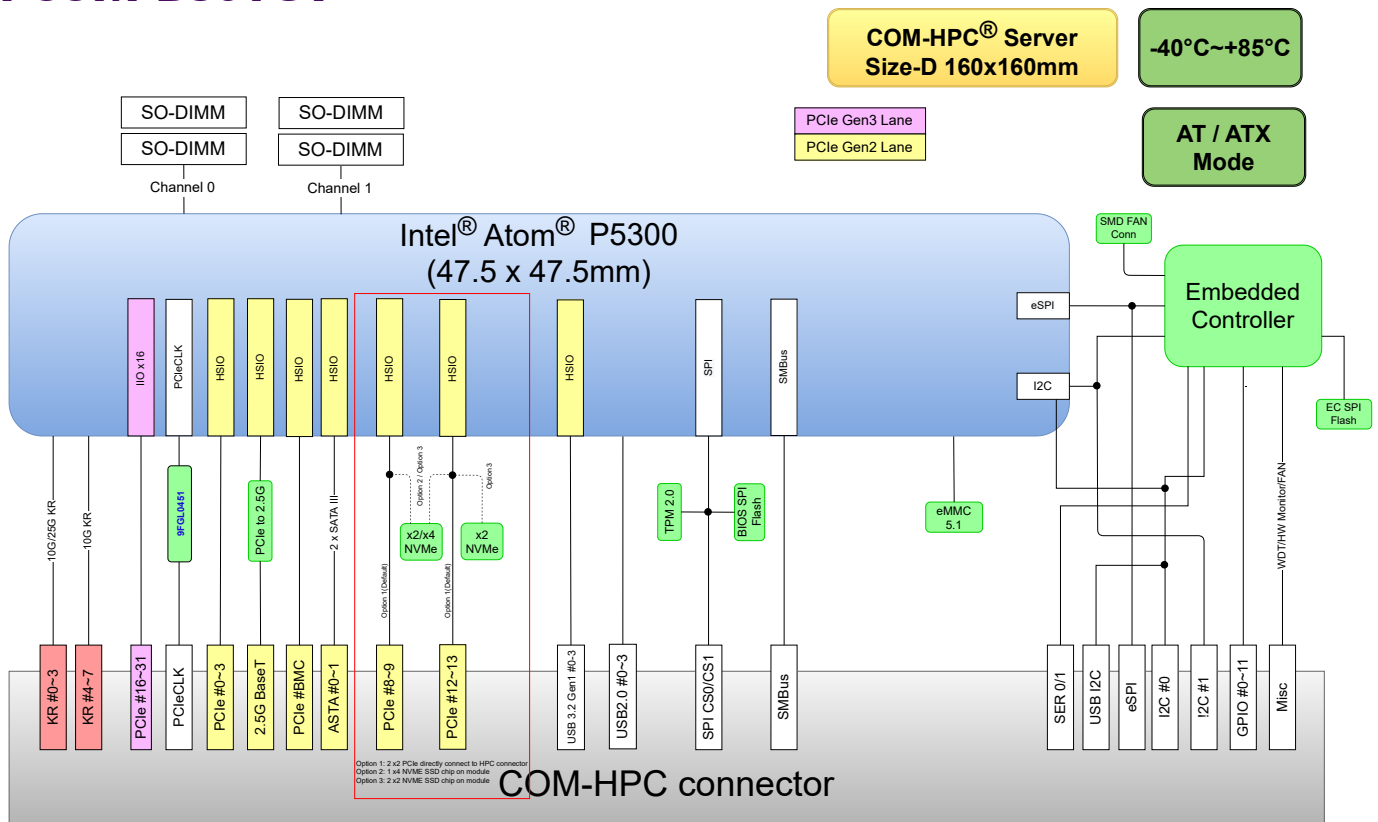

Portwell, Inc. Headquarters
No. 242, Bo' Ai St., Shu-Lin Dist,
New Taipei City 238, Taiwan
Tel: +886-2-7731-8888
Fax: +886-2-7731-9888
E-mail: info@portwell.com.tw
www.portwell.com.tw

American Portwell
(Fremont, CA)
Tel: +1-510-403-3399
E-mail: info@portwell.com
www.portwell.com

Portwell Japan, Inc.
(Tokyo)
Tel: +81-3-6902-9225
E-mail: info@portwell.co.jp
www.portwell.co.jp

European Portwell
Tel: +31-252-620790
E-mail: info@portwell.eu
www.portwell.eu

Shanghai Portwell
Tel: +86-21-5771-2505
E-mail: info@portwell.com.cn
www.portwell.com.cn

Portwell India Technology Private Limited
Tel: +91-80-4168-4255
E-mail: enquiry@portwell.in
www.portwell.in

Portwell UK Ltd.
Tel: +44(0)1235-750-760
E-mail: info@portwell.eu
www.portwell.eu

Portwell Japan, Inc.
(Osaka)
Tel: +81-6-4807-7721
E-mail: info@portwell.co.jp
www.portwell.co.jp

KIOSK Embedded Systems GmbH
Tel: +49-8152-3962-500
E-mail: info@portwell.eu
www.portwell.de

Portwell Korea, Inc.
Tel: +82-31-450-3043
E-mail: info@portwell.co.kr
www.portwell.co.kr

